

# HOTLOK®



## HotLok® Round 4" Rack Mount Grommet

Part Number

40002



Round 4" Rack Mount Grommet - Part No. 40002

### Applications

Designed to seal 4" (102mm) cable openings in new and existing server rack cutouts to block bypass airflow and maximize cooling system efficiency.

HotLok Round Rack Mount Grommet, the latest patented thermal management solution is the premium choice for your facility. Its revolutionary sealing technology greatly reduces costly bypass airflow, increasing usable cooling unit capacity, and ensuring maximized efficiency from HVAC equipment.

### Features

- The Split feature of the HotLok Round Rack Mount Grommet allows product installation or removal without disturbing cables
- The Grommets contain no loose or partially fastened parts, which can become separated or fall into the rack
- The Grommets are impact resistant and durable
- HBT Membrane Layer ensures maximum air containment
- HotLok products are compliant with directive 2002/ 95/ EC of the European Parliament and the Council on the Restriction of the Use of Certain Hazardous Substances in Electrical and Electric Equipment (RoHS)
- The Grommet features a membrane support structure

### Benefits

- Supports increasing cabinet density
- Increases existing cooling unit capacity
- Reduces the need to purchase additional cooling units
- Improves IT equipment reliability and extends equipment life
- Simple snap in place, installation saves time and labor and requires no downtime
- Round grommets enable hole saw installation
- Most cost effective tool for cable separation and cable management while minimizing bypass airflow in the rack
- Durable ABS frame and Hybrid Brush sealing surface can be used for years
- Hybrid Brush Technology (HBT) provides the most effective air seal in the industry and avoids sagging bristles

### Hybrid Brush Technology (HBT)

HBT is uniquely constructed to offer:

- Flexible and highly efficient sealing membrane
- Membrane supports bristles to reduce sagging and limit leakage
- Multi-layered construction for increased sealing effectiveness
- Color: Black

## Specifications

Dimensions and Cutting Requirements	Inches	Millimeters
Part No. 40002 - Overall size (diameter x height)	5.60" x .7"	142 x 18mm
Product height above the rack	.40"	10mm
Maximum thickness of plate at rack install location	.0625"	1.6mm
Hole cut required for installation	4.0" - 4.08"	101.6 - 103.6mm
Usable cable area	9.6" sq. inch	6194 sq. mm

### Patented Sealing System

U.S. and International patented Hybrid Brush Technology (HBT) design using thermoplastic elastomer creating a more effective seal than any other grommet. Tear lines minimize leakage in unused areas of the grommet when only a small number of penetrants are being used.

U.S. and International patented: single-layer, opposing and interwoven filaments ensuring flexibility and self-sealing recovery along with guaranteeing passage of 30 amp power connector.

### Sealing Effectiveness

New, patented Hybrid Brush Technology (HBT) offers exceptional sealing and airflow management, unsurpassed by other leading brush products on the market today. Hybrid Brush Sealing Technology automatically seals around cables with no additional maintenance or monitoring required.

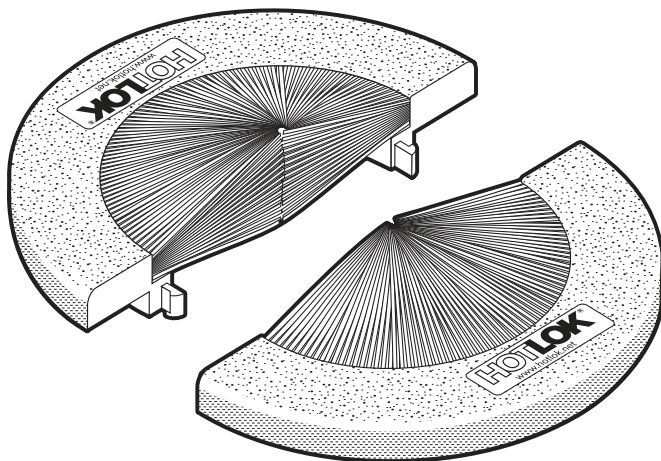

### Grommet Frame

The frame is molded from durable ABS

Finish: Black

### Rack Mounting System

Four (4) integrated self-securing molded clips ensure grommet is firmly fastened to the rack.

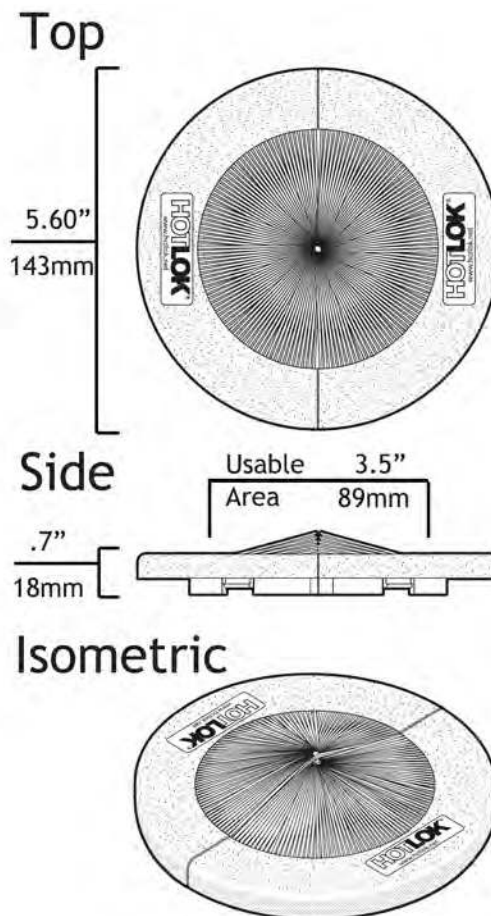

**upsite**  
technologies®

Designer & Manufacturer  
(888) 982-7800 www.upsite.com

**ProSource**®  
MISSION CRITICAL SERVICES

The right choice for mission critical data centers